

Type	Number of step output contacts	Supply voltage (V) 50/60 Hz network	Measuring voltage (V)	
N-6	6	110-220/240-380/415	110-220/240-380/415	
N-12	12	110-220/240-380/415	110-220/240-380/415	
NC-12	12	110-220/240-380/415	110-220/240-380/415-690	
Optional accessories				
Communication, RS 485/Modbus, adapter for NC-12				
External temperature probe for NC-12				
Data supplied			N-6/N-12	NC-12
Cos φ			x	x
Connected steps			x	x
Switching counter and duty cycles			x	x
Network technical data: I, U, S, P, Q			x	x
Temperature of the capacitor bank			x	x
Total voltage harmonic distortion THD (U)			x	x
Alarm log			x	x
Step status (fixed, auto, disconnected)				x
Step capacitance monitoring				x
Total current harmonic distortion THD (I)				x
Capacitor overload Irms/I1				x
Voltage and current harmonic spectrum				x
Alarm	Thresholds	Actions	N-6/N-12	NC-12
1. Low power factor		Message and alarm contact	x	x
2. Hunting (unstable regulation)		Message and alarm contact, stops regulation for 10 minutes	x	x
3. Abnormal cos φ	< 0.5 ind or 0.8 cap	Message and alarm contact	x	x
4. Low voltage	< 80 % U within 1s	Message and alarm contact, step disconnection	x	x
5. Overcompensation		Message and alarm contact	x	x
6. Wrong frequency		Message and alarm contact, stops regulation	x	x
7. Overcurrent	> 120%	Message and alarm contact	x	x
8. Overvoltage	> 110% U	Message and alarm contact, step disconnection	x	x
9. Overtemperature	> 35°C ⁽¹⁾	Fan switch contact	x	x
	> 50°C ⁽¹⁾	Message and alarm contact, step disconnection	x	x
10. Voltage distortion	> 7% ⁽¹⁾	Message and alarm contact, step disconnection	x	x
11. Capacitor overload	Irms/I1 > 1.3 ⁽¹⁾	Message and alarm contact, step disconnection		x
12. Capacitor output low	< 75% of nominal	Message and alarm contact, step disconnection		x

⁽¹⁾ alarm threshold values can be configured

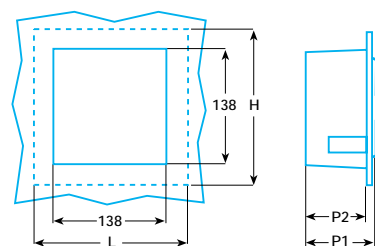

Type	Dimensions (mm)				Weight (kg)
	H	L	P1	P2	
N-6/N-12	155	155	70	60	1
NC-12	160	155	75	65	1

POWER FACTOR CONTROLLERS N-6, N-12 AND NC-12

... ENHANCE THE OPERATION OF YOUR CAPACITOR BANK

Nokian power factor controllers provide your network with efficient reactive power compensation, measuring and supervision. The applications include automatic control of low and medium voltage capacitor banks (tuned, detuned and conventional).

... IMPROVE USER-FRIENDLINESS AND CONDITION MONITORING

Improved user-friendliness due to multi-lingual user-interface, clear text and symbol messages, graphics, alarm log and communication.

Nokian Power Factor Controller offers advanced condition monitoring for your network as well as for the capacitor bank. The supervision and condition monitoring functions add to the simplified programming with intelligent self set-up ensure optimal use of reactive power compensation system.

IMPROVED POWER FACTOR, COS φ , RESULTS IN

- lower energy consumption and costs
- more power transmission capacity via network
- less power loss in network
- lower transformer losses
- stable voltage level in power distribution networks



TAKE THE STEP TOWARDS INTELLIGENT POWER FACTOR CONTROLLING

N-6 AND N-12

OPTIMIZED USER INTERFACE FOR EASY OPERATION

Backlighted alphanumeric multisymbol LCD-display and ergonomic push buttons enable:

- viewing of electrical information
- easy browsing in the menus
- multilingual usage
- alarm indications

PERFORMANCE

- intelligent stepping algorithm for optimum step utilization and fast response
- all traditional stepping sequences also available

SIMPLIFIED INSTALLATION AND SET-UP

- quick and simple mounting and wiring
- insensitive to current transformer polarity and phase rotation polarity
- a special menu allows controller self-configuration

MONITORING AND PROTECTION

Alarms

- should a disturbance occur on the network or in the capacitor bank, alarms are indicated on the screen and alarm contact closure is initiated
- the alarm message is maintained on the screen once the fault clears and until it is manually reset
- last five alarms are stored in alarm log

Protection

- if necessary, the capacitor steps are automatically disconnected to protect the equipment

N-12 CONNECTION EXAMPLES

Line-to-Line connection

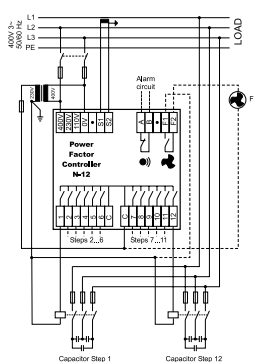

Line-to-Neutral connection

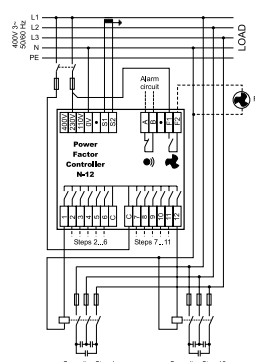

NC-12

FOR MORE ADVANCED POWER FACTOR CONTROLLING

In addition to the functions of N-6/N-12, the NC-12 provides the following additional features:

- measurement of total current harmonic distortion
- graphical analysis of network harmonic currents and voltages
- possibility of a dual target $\cos \varphi$
- possible to configure steps permanently switched off or on
- step condition monitoring
- time stamped alarm log
- on-line help menus

A COMMUNICATING MODEL

- optional communication auxiliary (RS485 Modbus)

NC-12 CONNECTION EXAMPLES

Line-to-Line connection

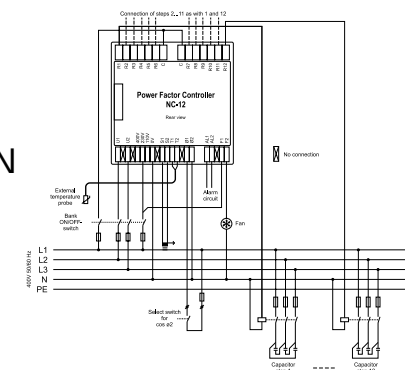

Line-to-Neutral connection

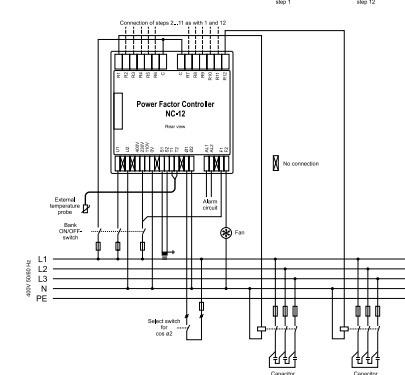

TECHNICAL SPECIFICATION

General data

- Operating temperature: 0...60°C
- Storage temperature: -20°C...60°C
- Colour: RAL 7016
- Standards: EMC:
 - immunity according to IEC 61000-6-2
 - emissions according to IEC 61000-6-4
- Electrical safety and low voltage directive according to IEC 61010-1
- Mounting mechanism: panel mounting, 138mmx138mm panel cutout or mounting on 35mm DIN-rail (EN 50022)
- Protection class: IP 41 front face, IP 20 rear face
- Display type:
 - N-6 and N-12 backlighted symbol LCD
 - NC-12 backlighted dot matrix LCD
- languages: English, German, French, Portuguese, Spanish, Swedish, Finnish
- Alarm contact
- Separate fan relay contact
- Temperature measurement:
 - N-6 and N-12 with internal temperature probe
 - NC-12 with optional external temperature probe
- Alarm log
- Serial communication port: RS 485, industry standard buses with optional communication adapter (NC-12 type)

Inputs

- Type of connection: phase to phase or phase to neutral
- Insensitive to CT polarity
- Insensitive to phase rotation polarity
- CT ratio range: 25/5A...6000/5A (all types)
- CT ratio range: 25/1A...6000/1A (NC-12 type only)

Outputs

- potential free output contacts:
 - AC: 1A/400V, 2A/250V, 5A/120V
 - DC: 0.3A/110V, 0.6A/60V, 2A/24V

Settings and parameters

- Target $\cos \varphi$ setting: 0.85 ind...0.90 cap
- Dual target $\cos \varphi$ with external control input (NC-12 type)
- Manual or automatic setting of all controller parameters
- Stepping programs: stack, normal, circular, optimal
- Various number of step size combinations
- Reconnection delay:
 - N-6, N-12: 10...600s
 - NC-12: 10...900s
- Step configuration: fixed, auto, disconnected (NC-12 type)
- 4-quadrant generator application
- Manual stepping