

FISHER PIERCE

SERIES 4500



AutoCap™

Adaptive Capacitor Controller-Recorder With Two-Way Communications

The Fisher Pierce Series 4500 AutoCap Controller-Recorder combines the intelligence of the AutoCap Adaptive Capacitor Controller with data radios for the cost effective automation of switched capacitors. Combining a capacitor control with two-way communications provides a powerful tool for discrete feeder management, data gathering, trouble shooting, system evaluation and analysis.

Integrated two-way communication is achieved by incorporating the data radio and capacitor controller in the same enclosure, eliminating the need for additional communication equipment. Communications management and protocol conversion is performed using a dedicated high speed processor and flash memory. This permits remote protocol changes and upgrade without the need for costly field modifications. The Fisher Pierce Series 4500 allows complete control flexibility using two-way communications. The controller can be configured to operate under SCADA control or as a local control with SCADA override.

The AutoCap controller with cellular telephone and modem provides instant trouble free, two-way communications. Using any PC/modem and Fisher Pierce SmartSet™ application software, which is Windows-based and menu driven, the user can program the controller, monitor real-time line conditions, retrieve and graph load survey data.

The controller can be used as an analytical tool - moving it from site to site for verification of capacitor bank operation, load study and investigation of troublesome feeders.

As a multifunction one-to-four season controller, the AutoCap can operate on the basis of VAR, voltage, current, temperature, time and combinations of these functions. In addition, AutoCap includes complete load data and event recording; reports can be created directly using SmartSet.

Capacitor Controller Features

- Adaptive VAR™ control.
- Voltage Guard™ (adaptive voltage restraint).
- PhaseFind™ (adaptive wiring corrections)..
- Windows-based SmartSet application software.

Communications Features

- Separate high speed communications processor.
- Flash memory allows remote change of protocol.
- Factory installed radio, modem or cellular telephone.
- Real-time monitoring and control.

Exclusive AutoCap™ Advantages

The Series 4500 AutoCap controller includes many new and innovative local control functions which eliminate the traditional struggle associated with setting optimum VAR setpoints (Fig. 1 – Adaptive VAR); finding the voltage change caused by bank switching (Fig. 2 – Adaptive Voltage Guard); and field wiring (Fig. 3 – PhaseFind).

• **Reverse power functions** calculate proper VAR setpoints to compensate for altered VAR measurement during this condition. Four other control mode options are also available for use during reverse power conditions. An LED on the controller panel indicates reverse power condition.

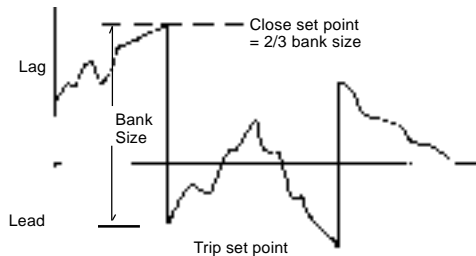

Adaptive VAR (Fig. 1)

Identifies size of the capacitor bank and sets the VAR switching points for maximum loss reduction.

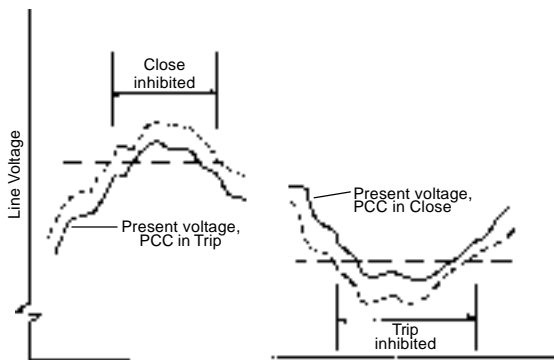

- **Reverse Trip/Close detection** automatically senses reverse wiring of the Close and Trip drive circuits to the capacitor switch; inhibits all switching, except manual, and indicates error by flashing LED on front panel.
- **Anti-hunt function** automatically compensates for rapid bank tripping due to cycling loads or interaction from other switched banks on the feeder.
- **Undervoltage inhibit** feature protects the capacitor bank switch from damage caused by low voltage.

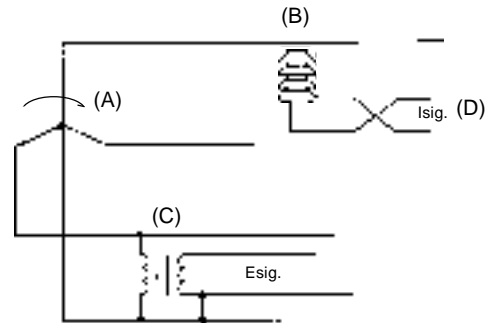

PhaseFind (Fig. 3)

Compensates for phase rotation (A), finds current signal phase (B) with respect to voltage phase (C), and compensates for reversed wiring (D).

Adaptive Voltage Guard (Fig. 2)

Identifies voltage change from bank switching; inhibits Close operation if Voltage Guard plus present line voltage exceeds high voltage limit. Reverse conditions inhibit Trip.

Additional AutoCap Features

The AutoCap controller builds on more than 30 years of Fisher Pierce experience in the design, manufacture, and application of electronic capacitor controls.

- Standard meter socket mounting, pole or wall mounting available.
- Single phase line current signal input: Line post sensor or CT input for VAR and current control and data recording.
- Capacitor bank neutral current signal input: Fisher Pierce split lamination sensor (AT929) or CT/VT neutral current input.
- Neutral current lockout lamp; reset by manual button or command through RS-232.
- Shielded ambient temperature sensor.
- 9 Pin, RS-232 communications port.
- Optical communication port available.
- 365/366 day time clock includes next century.
- Programmable momentary output relays.
- Nonvolatile memory.
- Independent watchdog timer.
- Electromechanical operations counter available.
- Internal LCD read/write display available.
- Operational status LED's.
- Manual Close/Trip operation and Auto/Manual switches.

SmartSet Application Software

The Series 4500 AutoCap controller is programmed using Windows-based SmartSet software created by Fisher Pierce for greater programming ease.

Using SmartSet software, the AutoCap is a multi-function microprocessor based controller which can be programmed for up to four seasons. Each season can have its own primary and override functions as listed in the Control Modes table below. The PCC is programmed via a standard RS-232 or optional optical communications port using any Windows-based PC.

Control Modes

Basic Functions	Override Functions	Voltage Bias	Reverse Power
<ul style="list-style-type: none"> Adaptive VAR VAR Voltage Current Time High Temp Low Temp 	<ul style="list-style-type: none"> Voltage Time High Temp Low Temp 	<ul style="list-style-type: none"> Time High Temp Low Temp 	<ul style="list-style-type: none"> Ignore Voltage VAR Trip and Inhibit Close and Inhibit

The following additional functions are also provided:

- **Real-time monitoring** of data readings and controller status through local RS-232 or optical port.
- **Traditional holiday calendar** – 10 year predefined, can be user edited.
- **Individual and block holidays** – 10 year user programmable.
- **Daylight Saving Time calendar** – 10 year predefined, can be edited.
- **Daily close count limit** - User programmable.
- **Switching time delays/inhibits** – For automatic and manual modes with LED indication on controller panel.
- **Neutral current lockout** – Trips bank and prevents further capacitor operation, and flashes external lamp in the event of a capacitor can failure. Reset by external button or RS-232 command.

View Setup Screen – allows user to review controller setup and site configuration summary.

Season Configuration Screen – fully prompted for easy controller programming.

Extensive Data Recording

The Series 4500 AutoCap PCC provides a full spectrum of user defined load data and controller operations recording capability. Three-phase load data are derived from single phase measurements and assume balanced load. All recorded data are easily uploaded via RS-232 or optional optical port. Memory of 32K standard; expanded 128K is available.

Data Recording Parameters

Load Data Recording

(1 min. to 4 hour averaging period)

Date/Time Stamp
Voltage (Secondary)
Current (Single phase)
kVA (3 ϕ)
kVA (3 ϕ)
kW (3 ϕ)
Power Factor
Total Harmonic Distortion
Temperature
Trip/Close Status

Daily Summary Recording

Date Stamp
Time of Max/Min Values
Daily Max/Min Voltage
Daily Max/Min Current
Daily Max/Min (3 ϕ) kVA
Daily Max/Min Temp
Daily Close Operations
Daily Close Hours
Close Ops Running Total

Operations Recording

Date/Time Stamp
Basic Operations
Override Operations
Manual Operations
Power up/Power down
Voltage Before/Delta Voltage
kVA Before and After
kW Before and After
Reverse Power/Normal Power

Report Generation Capability

The SmartSet™ report generation feature provides spreadsheet format and visual presentation of recorded data as well as many editing features. This capability is integrated into SmartSet—no additional software is required. The ability to graph all load study data, specify time period, and superimpose Close/Trip operations is included.

Load Data Reports

- Spread sheet format file
- Direct graphing of load data
- Direct edit graph time period
- Trip/Close status
- Report printing

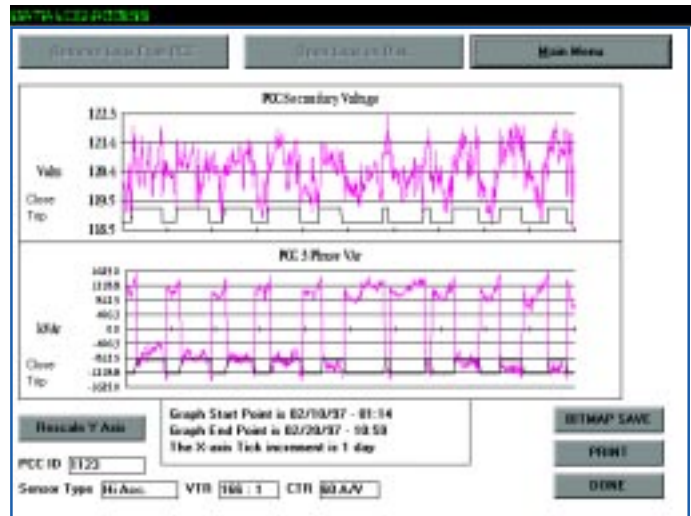

Typical Load Data Graph

Specifications:

SERIES 4500 AUTOCAP™ CONTROLLER AND RECORDER WITH TWO-WAY COMMUNICATIONS

RADIO

Maximum Radio Dimensions: 13.50"h x 7.25"w x 2.25"d
Radio Power Supply: 13 Vdc, 2.0A continuous, 3.0A transmit

ELECTRICAL

Operating Voltage Ranges: 95 – 140 V, 60 Hz
 190 – 280 V, 60 Hz
 95 – 125 V, 50 Hz
 190 – 250 V, 50 Hz

Surge Withstand: ANSI C62.41-1987

Electrostatic Discharge Test: 15kV applied to all accessible parts, IEC 801-2.

Output Relay:

Number: Two
Type: Momentary closure
Maximum Continuous Load: 10A
Maximum Inrush: 50A, 50% PF, 6 cycles, make only
Contact Closure Period: Programmable 1 - 120 seconds, in 1 sec. increments

Fuse Rating:

Output to Capacitor Switch: 10A FNM Slo-Blo® load fuse.
Controller Input: 2A controller fuse.

RS 232 Communications Port: DB9 female connector

Optical Communications Port: Type 2

MECHANICAL

Enclosure: Luran, NEMA 3R
Mounting: 4 or 6 jaw meter base, wall or pole bracket
Dimensions: 15.25"h x 9.25"w x 8.50"d

ENVIRONMENTAL

Operating Temperature: -40° C to + 80° C
 (-40° F to +176° F)
Humidity Range: 0 to 95% (non-condensing)

MEASUREMENT PERFORMANCE

Voltage
Secondary
Resolution: 0.1 Vac
Accuracy: ±0.5% of reading over temperature.
Range: Same as operating range, true rms
Primary

VT Ratio Range: 1 : 1 to 1000 : 1 in 0.1 : 1 increments
Current

Resolution: Fisher Pierce 1301 sensor: 0.1A
 Lindsey line post sensor: 0.1A
 Current transformer: 0.01A (secondary)

Accuracy: ± 1.0% Reading, ± 0.2% Range, ± sensor error.

Range: Fisher Pierce 1301 sensor ... 4-800A true rms
 Lindsey line post sensor: 4-800A true rms.
 Current transformer: 0.1 – 20A
 (secondary) true rms
 Current Transformer Ratio (CTR): 5:5 to 2000:5
 in 1:5 increments.

Reactive Power (VAR): Resolution: 1kVAR
Range: ±99,999kVAR

Temperature: Resolution: 1° F (1° C)
Accuracy: ± 4° F (2° C)
Range: -40° C to + 60° C (-40° F to + 140° F)

Time Clock: Resolution: 1 second
Accuracy: ± 10 minutes per year
Range: 24 hour clock
Settings: 1 minute increments

Phase Angle: Resolution: 0.1°
Accuracy: ± 1°, ± sensor error
Range: 0° - 359°

Neutral Current

Resolution: Fisher Pierce AT929 sensor: 0.1A
 Current Transformer: 0.01A (secondary)
 Potential Device: 0.1V (secondary)
Accuracy: ± 2% of reading, ± 1% range, ± sensor error
Range: Fisher Pierce AT929-400 sensor: 1 to 60A
 Current Transformer Ratio Sec: 5:5 to 2000:5
 Potential Device: 0-60V (secondary)

CONTROLLER PROCESSOR

Memory Size: 32 kB (standard), 128 kB (option)
Memory Types: EPROM, NVRAM and battery backed RAM

SERIES 1301 LINE POST SENSOR.

Calibration Accuracy at 120A: ± 1%
Linearity Error: 3-1200A, ± 1%
Angle Error: 3-600A, ± 0.5°
Temperature Error: ± 0.02% / °C
7th Harmonic Response: 82%

*See Fisher Pierce Series 1301 bulletin FP054 for complete specifications.

Ordering Information

Model	45	1	1	N	-	C	T	S	-	D	D	A	-	SK	6	1	B	-	
Section	1	2	3	4	-	5	6	7	-	8	9	10	-	11	12	13	14	-	15

Example

- Section 1 Basic Model Number**
45 Autocap programmable capacitor with two-way communications
- Section 2 Line Current Input (Current sensing device ordered separately).**
1 Fisher Pierce 1301 line post sensor (60A/V) or Lindsey sensor (100A/V)
2 CT (5A secondary)
0 None
- Section 3 Neutral Current Sensor**
1 Fisher Pierce AT929 sensor with 6 foot lead (supplied)
2 CT (not supplied)
3 VT (not supplied)
0 None
- Section 4 Optical Communication Port**
F Supplied
N None
- Section 5 Counter/Display**
C Electro-mechanical (counter 120Vac only)
D 2-line display only (read only)
E Electro-mechanical counter and 2-line display (read only)
N None
- Section 6 Temperature Sensor**
T Supplied
N None
- Section 7 Memory**
S Standard 32K
E Expanded 128K
- Section 8 Communications Protocol**
F SmartSet (no comm. micro or flash memory)
D DNP 3.0 (comm. micro and flash memory installed)
Note: For cellular phone or modem communication, select "F"

- Section 9 & 10 Circuitry To Support Cellular / Modem Communications**
MB Modem installed - PSTN (public service telephone network)

- Radio Communications**
BA Installed - Metricom model 20043
BB Radio Ready
DA Installed - MDS model 9310, 9810
DB Radio Ready
NC Communications ready or radio upgrade
Note: Installed = Radio installation by FP, supplied by customer.
Communication micro, flash memory and power supply included.
Radio Ready = Radio installed by customer. Radio bracket, antenna mount and cables included. Communication micro, flash memory and power supply included.
Communications Ready (defined by selecting "D" in section 8) = Radio bracket and cables not included. Power supply included. Comm. micro and memory installed.
Radio Upgrade (defined by selecting code "F" in section 8) = Radio bracket and cables not included. Power supply included. Comm. micro and memory not installed (Controller board change out required for communications using a protocol other than SmartSet).

Section 11 External Wiring and Mounting Configuration (See Below)

- Section 12 Enclosure Type**
6 Luran

- Section 13 Voltage/Frequency**
1 120 Vac, 60Hz
2 240 Vac, 60 Hz
3 120 Vac, 50 Hz
4 220 Vac, 50 Hz
5 240 Vac, 50 Hz

- Section 14 Factory Code**
B

- Section 15 SCADA Options**
D Two dry SCADA inputs - Internally wetted/
F Blown fuse detect (DNP 3.0 protocol)
W Two wetted SCADA inputs - customer wetted 40-140V (ac/dc)

Section 11 Four Jaw Meter Socket Mounting and Wiring

Section 11	1	2	3	4	5	6	External GND Lug	Current Inputs
FJ	L	N/GND	TR	CL	-	-	NO	NONE
GJ	L	N/COM	TR	CL	-	-	YES	NONE

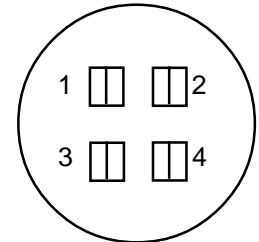

Section 11 Six Jaw Meter Socket Mounting and Wiring

Section 11	1	2	3	4	5	6	External GND Lug	Current Inputs
SJ	CSL	N/GND	L	TR	CSH	CL	NO	LINE ONLY
TJ	CSL	N	L	TR	CSH	CL	YES	LINE ONLY
SM	L	N/GND	CSL	CSH	TR	CL	NO	LINE ONLY
TM	L	N	CSL	CSH	TR	CL	YES	LINE ONLY
SL	L	N/GND	NSL	NSH	TR	CL	NO	NEUTRAL ONLY
TL	L	N	NSL	NSH	TR	CL	YES	NEUTRAL ONLY
SK	L	N/GND/COM	NSH	CSH	TR	CL	NO	LINE+NEUT
TK	L	N/COM	NSH	CSH	TR	CL	YES	LINE+NEUT

View looking into socket

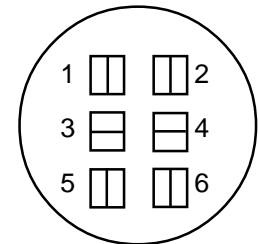

Section 11 Bracket Mounting with Terminal Strip

Section 11	External GND Lug	Current Inputs
BJ: POLE WJ: WALL	WIRE TO TERMINAL STRIP AS SHOWN BELOW	YES NONE, LINE, NEUTRAL OR LINE+NEUTRAL

Socket for CT shorting switch available for SJ and TJ wiring

Refer to Fisher Pierce product bulletin IC172-1293-4M-F for 2100 Series Meter Socket ordering information.

Terminal Strip

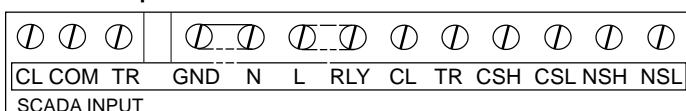

- CL=Close
- GND= System ground
- RLY= Output relay armatures
- CSH = Line current signal High
- NSH= Neutral current signal High
- COM=Com
- N= Neutral
- CL= Close
- CSL = Line current signal Low
- NSL= Neutral current signal Low
- TR=Trip
- L= Line
- TR= Trip

- Broken lines between terminals indicate removeable jumper

Mechanical Data

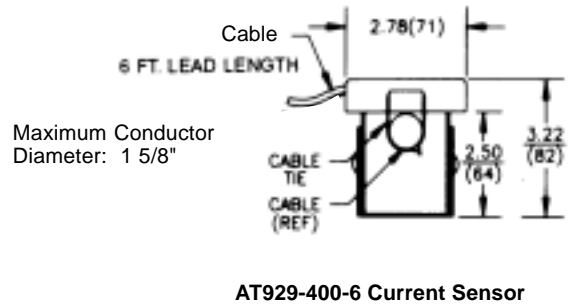
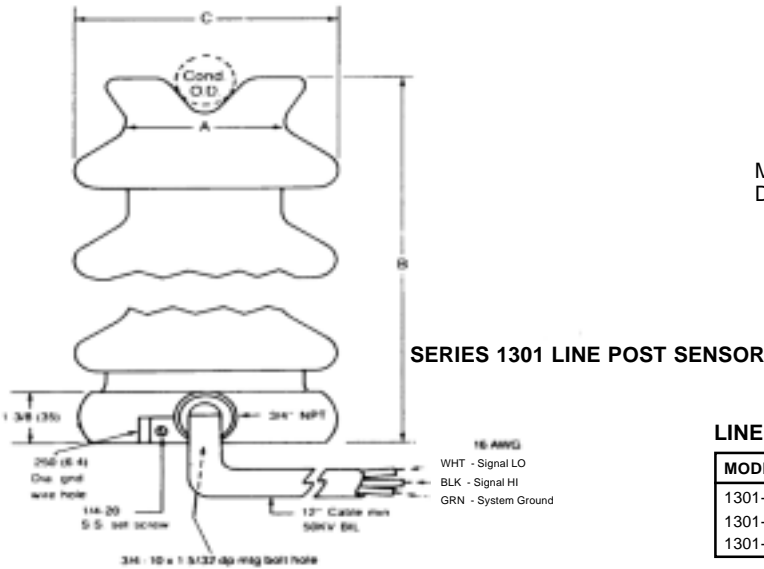
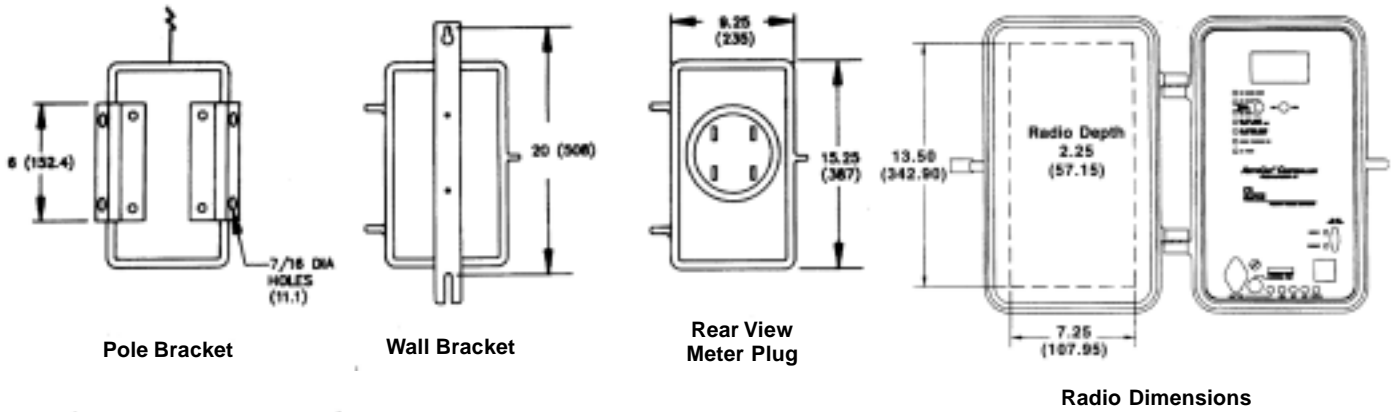

LINE POST SENSOR DIMENSIONS

MODEL	A	B	C	Max. Cond. Dia.
1301-11A & 17A (15KV)	3.3(84)	9.3(236)	5.6(142)	1.5(38)
1301-41A & 47A (25KV)	5.0(127)	12.5(317)	7.0(178)	2.0(38)
1301-21A & 27A (35KV)	5.0(127)	14.5(368)	7.0(178)	2.0(51)

Installation and Preferred Sensor Location

Notes:

1. 4W - grounded WYE circuit shown.
2. Refer to ordering information for wiring of other socket codes or terminal strip.
3. Refer to instruction manual for complete installation information.

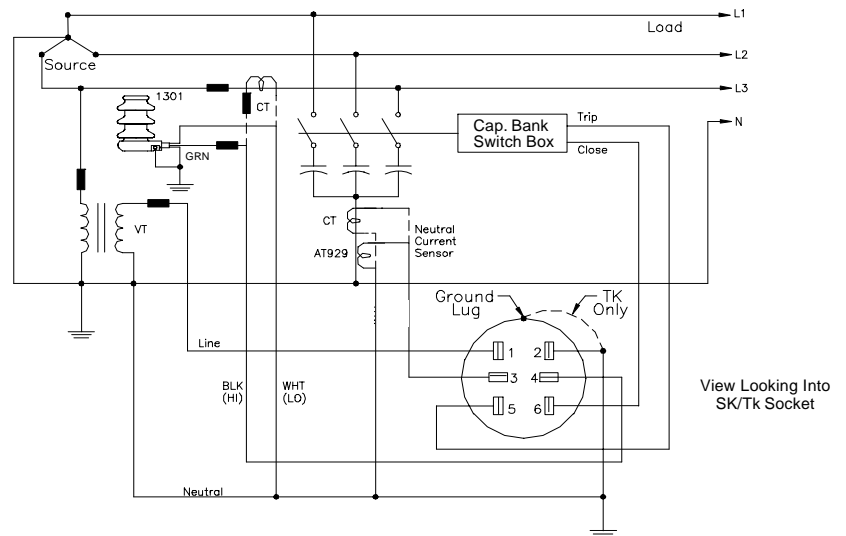

Specifications are subject to change.



4000 East 116th St., Cleveland, Ohio 44105-4398 USA
 Tel: (216) 271-6600 · Fax: (216) 341-3615
 www.joslynhivoltage.com
 Email: info@joslynhv.com